

# ELECTROMECHANICAL CYLINDERS

Operating Instructions translated from original

## Table of Contents

|   |    |
|---|----|
| <b>1. Health and Safety</b> .....   | 3  |
| 1.1 Notice about safety.....  | 3  |
| 1.2 Warning devices.....  | 4  |
| 1.3 Warnings and cautions.....  | 4  |
| <b>2. Safety of the Machinery</b> .....   | 4  |
| 2.1 When rebuilding the machine .....   | 4  |
| 2.2 Personnel requirements .....  | 4  |
| 2.3 Manufacturer .....  | 5  |
| 2.4 Mark .....  | 5  |
| 2.5 Working method in the event of an incident or breakdown.....                    | 5  |
| <b>3. Noise</b> .....   | 6  |
| <b>4. Safety Instructions</b> .....   | 6  |
| <b>5. Electromechanical cylinder Description and Maintenance instructions</b> ..... | 7  |
| 5.1 Product description .....   | 7  |
| 5.2 Drawing .....   | 7  |
| 5.3 Usage.....  | 7  |
| 5.4 Handling .....  | 8  |
| 5.5 Storage and Transport .....   | 8  |
| 5.6 Installation instructions.....  | 9  |
| 5.7 Commissioning.....  | 10 |
| 5.8 Maintenance.....  | 12 |
| 5.9 Lubricant.....  | 14 |
| <b>6. Appendix</b> .....  | 14 |
| 6.1 Installation of the positions sensors on the MCT75-MCT250 .....                 | 14 |

## 1. Health and Safety

These operating instructions contain the information necessary for the daily work of the operator responsible for the handling and usage of the equipment.

The operating instructions must be available to the persons involved in the operation of the equipment.

### It is important that:

- The operating instructions and other applicable documents are retained throughout the lifetime of the equipment.
- The operating instructions and other applicable document are included as part of the equipment.
- The operating instructions are passed on to all other users of the equipment.
- The operating instructions are updated following any additions or changes to the equipment.
- The operating instructions describe the methods required in the use of the equipment.

### 1.1 Notice about safety

Before you start to use the equipment, or to perform maintenance or servicing of the equipment, please read the relevant parts of these instructions.

Pay attention to all the Danger, Prohibition, Edict, and Note textboxes mentioned in this manual.

Serious damage to persons and machinery can occur if this information is not observed.

The machinery is intended for use by an authorised operator.

Consider all electrical equipment to be live.

Consider all the hoses and pipes to be pressurised.

During servicing and maintenance of the equipment / machine, ensure that the source of power to the electricity, pneumatics (air) and hydraulic is broken before any maintenance is performed. The machine must be vented and the safety switch should be locked.

Servicing and maintenance should only be performed by qualified service personnel.

Follow the instructions in terms of the maximum loads, and see the decal on the equipment for the technical data.

## 1.2 Warning devices

Annual checks of warning devices and protective devices must be implemented to maintain control of their function and status.

## 1.3 Warnings and cautions

The Danger, Prohibition, Edict and Note textboxes contain information that is of importance in this manual:

(see the pictures below).

|   |   |
|---|---|
|  | <b>DANGER!</b><br>Ignoring this information will result in immediate danger to life!! |
|---|---|

|   |  |
|---|--|
|  | <b>PROHIBITION!</b><br>Prohibited act associated with death or serious injury! |
|---|--|

|   |  |
|---|--|
|  | <b>EDICT!</b><br>Correct use of personal protective equipment or other aids. |
|---|--|

|  |  |
|--|--|
|  | <b>NOTE!</b><br>Information that requires extra attention! |
|--|--|

## 2. Safety of the Machinery

The machine is labelled with a CE mark, see 2.4, which means that it has been designed, constructed and described in accordance with the EU Machinery Directive 2006/42/EC.

### 2.1 When rebuilding the machine

If the machine is rebuilt or supplemented with other parts that are not approved by the manufacturer, the CE mark does not apply for the parts that have changed the machine's functions. Warning labels and the CE mark must be clearly visible on the machine. If the warning label for a machinery part is replaced, then the new warning label should be installed in the same place as before.

Damaged decals and CE marks must be replaced immediately.

If the machine is rebuilt or parts are added, it is very important that these instructions are immediately completed / adjusted with the necessary illustrations, photographs and texts.

### 2.2 Personnel requirements

To avoid damage or injuries, the operator and operating personnel must be specifically instructed or trained according to the manufacturer's instructions. Operators and operating staff may only handle those parts that they have been instructed or trained to use.

All controls and keys shall be operated by hand and should never be activated by means of another kind, unless it is otherwise provided.

## 2.3 Manufacturer

This machine is manufactured by:  
Swedrive AB  
341 51 Lagan  
SWEDEN

## 2.4 Mark

This machine is supplied with the following mark:

|                             |                    |           |       |
|-----------------------------|--------------------|-----------|-------|
| <b>SWEDRIVE</b>             |                    | <b>CE</b> |       |
| Type                        | 92062101           | Ratio     | 32:1  |
| No                          | 149508-09          | YY/WW     | 17/44 |
| Lubr                        | MOBIL GLYGOYLE 460 |           |       |
| SWEDRIVE AB, SE-34151 LAGAN |                    |           |       |

### Type of mark

The serial number is given in the "No." field.  
This matches the Swedrive order number and must always be given in matters relating to the electromechanical cylinder.

## 2.5 Working method in the event of an incident or breakdown

The electromechanical cylinder is normally built into another machine and before starting up this machine, the operator and installer must be trained in the correct procedure in the event of an accident or breakdown on this machine.



If the following has happened, the electromechanical cylinder should not be used, contact Swedrive before the electromechanical cylinder perhaps could be put back into operation again.

- The electromechanical cylinder has been driven into external or internal stop.
- Movement between normally fixed parts can be observed.
- Temperatures above 100° C on the electromechanical cylinder have been measured.

If the following can be observed, the electromechanical cylinder should not be used before the cause has been investigated. If necessary, contact Swedrive.

- External damage to the electromechanical cylinder can be observed.
- The electromechanical cylinder does not move during commissioning of the motor.
- The motor power has for a long time continuously increased during operation.
- Abnormal noise during operation.

If an electric motor/hydraulic motor is used, see the motor operating manual for working methods in the event of an accident or breakdown.

**In the event of an accident with personal injury, call 112 immediately and contact healthcare.**

### 3. Noise

This machine features a continuous A-weighted sound pressure level that is below 70 dB (A).

### 4. Safety Instructions

- The machine may only be used by trained personnel and when the user has read and understood the contents of the current operating instructions.
- The machine may only be used for its predetermined purposes and only with the installed protection devices. All applicable safety regulations must be observed.
- Daily maintenance work must be performed by trained personnel.
- Electrical work must only be performed by trained personnel.
- Work on live electrical parts is not permitted.
- Rebuilds, repairs and modifications to the machine may only be performed under the applicable safety regulations.
- When repairs are performed, it is only permitted to use the original spare parts.

## 5. Electromechanical cylinder Description and Maintenance instructions

### 5.1 Product description

The electromechanical cylinder consists of gearbox (worm gear) that transfers the rotational motion to an axial motion. A spindle is fixed into the worm wheel. By rotating the worm wheel / spindle and by fixing the trapezoid nut into the piston rod in combination with the rotational locking of the end eye of the electromechanical cylinder, the end eye will move axially.

### 5.2 Drawing

If the field "Type" on the machine plate starts with no. 9 or G, contact Swedrive for correct drawing. For other electromechanical cylinders, see drawings in Swedrive's electromechanical cylinder catalogue

### 5.3 Usage

The electromechanical cylinder is designed to move loads horizontally (pull / push) or vertically (raise / lower). Only the axial forces should affect the electromechanical cylinder. Therefore, the load must be steered so that no radial forces will affect the electromechanical cylinder (see Section 2 of the Installation Instructions).

If there is a risk of personal injury or if unwanted damage to the machinery could occur, the electromechanical cylinder should be supplemented with another safety system. Other uses of the electromechanical cylinder than those described above may only be done with the permission of the manufacturer.

None of Swedrive's electromechanical cylinders are completely dynamic self-locking. Electromechanical cylinders with single thread spindles are good static self-locking. When demanding absolute static self-locking or using electromechanical cylinders with double thread spindle, supplement the electromechanical cylinder with a brake. In case of uncertainty about self-locking, contact Swedrive.



**Warning!** If the electromechanical cylinder is assembled in such a way that people are at risk of injury from contact with the piston rod when it is in motion, the builder of the machine is responsible for ensuring that the piston rod is protected against any such contact.

Use an electromechanical cylinder of the right size – if in doubt, check the specifications in our electromechanical cylinder catalogue or contact Swedrive.



**WARNING:**

**The electromechanical cylinder alone is not a safety device. In cases where there is a risk of personal injury, the electromechanical cylinder should be supplemented with an alternative safety system.**



## 5.4 Handling

When unpacking and installing the electromechanical cylinder, the weight of the electromechanical cylinder and the motor must be taken into consideration. See the electromechanical cylinder catalogue for information about the weights.

## 5.5 Storage and Transport

The electromechanical cylinder must be stored or transported in a way that will prevent exposure to rain, high temperatures, ozone or solar radiation which can cause premature aging of the rubber components. The relative humidity should be kept below 50% to minimise condensation on the electromechanical cylinder. At storage the ambient temperature should be in the range of 0 to +30° C. If a prolonged storage time, storage or transport with relative humidity above 50%, storage or transport in difficult conditions is necessary, please contact Swedrive for further information, also see storage and transport instruction SW3046.



## 5.6 Installation instructions

1. Make sure that the end eye is clean and filled with grease. If maintenance-free end eye is used, do not add lubrication.
2. If possible, mount the electromechanical cylinder in a retracted position to protect the piston rod.
3. The electromechanical cylinder must be free from any side forces. Side loads must be controlled with a guidance system, or similar, so that only the pull or push loads will affect the electromechanical cylinder.



4. Make sure that no stresses are built into the electromechanical cylinder during the assembly.
5. When combining multiple electromechanical cylinders with a drive motor, gearboxes and intermediate axles, these must be carefully aligned.
6. If the electromechanical cylinder (or electromechanical cylinders) is correctly mounted, you will be able to rotate the incoming shaft by hand when the electromechanical cylinder is unloaded.
7. Be sure to protect moving/rotating parts from accidental access.



8. If a sensor is used, think about the consequences of a malfunction / voltage loss!
9. If the electromechanical cylinder is mounted in a humid environment and powered by an electrical motor, on the electric motor ensure that the lowest of the drain plugs is opened.

## 5.7 Commissioning

1. Do not operate the electromechanical cylinder unless all limit sensors or possibly safety devices are installed and working properly.



**NOTE!**

**Never run the electromechanical cylinder unless the end positions sensors are installed and working properly, see point 7 and 8.**

2. If an electric motor is used, it should be installed and commissioned according to its operating instructions.  
Check that the actual voltage matches the specified voltage.  
The staff member who connects the electricity should have the necessary skills and qualifications.



**WARNING!**

**The staff member who connects the electricity should have the necessary skills and qualifications.**

3. Prior to start up, check that there is sufficient lubricant in the gear case of the electromechanical cylinder. For the type and amount of lubricant, see Section 5.8 Lubricant.
4. If permitted, it is advantageous to charge the electromechanical cylinder with only half the load from the start. After a number of runs, you can increase this to the full load. If abnormally high temperatures occur, investigate the cause and be aware of the risk of fire!
5. Make sure that the electromechanical cylinder never runs into external mechanical stop.



**NOTE!**

**Never run the electromechanical cylinder into the external or internal mechanical stops. This could serious damage the electromechanical cylinder.**

6. Make sure that the electromechanical cylinder never runs into internal mechanical stops. The electromechanical cylinder has warning zones (see the pictures below) to allow the operator to visualise the danger and to avoid running into internal mechanical stops, in order not to damage the electromechanical cylinder. Therefore, during its operation, the operating distance must be adjusted so that the electromechanical cylinder never runs into the warning zones. See point 7 and 8.

7. **Adjusting the end position sensor when driving the electromechanical cylinder outwards.**  
When Line 1 is visible outside the edge of Wiper 3, the electromechanical cylinder has reached the outer warning zone and the electromechanical cylinder must be stopped within 5 mm, before reaching Line 2. Driving outwards after reaching Line 2 will lead to electromechanical cylinder damage.

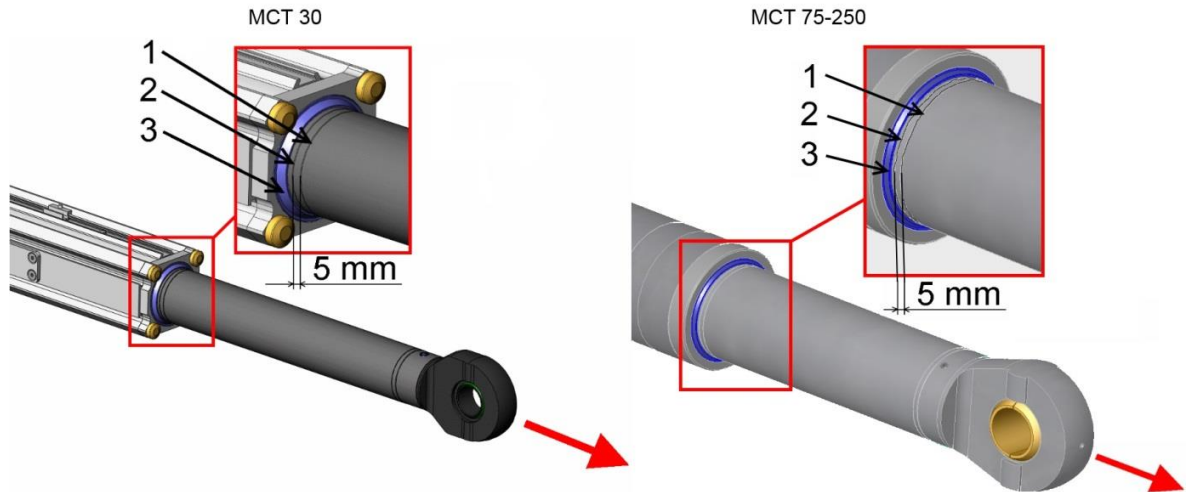

8. **Adjusting the end position sensor when driving the electromechanical cylinder inwards.**  
When Line 4 reaches the edge of Wiper 3, the electromechanical cylinder has reached the inner warning zone and the electromechanical cylinder must be stopped within 5 mm, before reaching Line 5. Driving inwards after reaching Line 5 will lead to electromechanical cylinder damage.

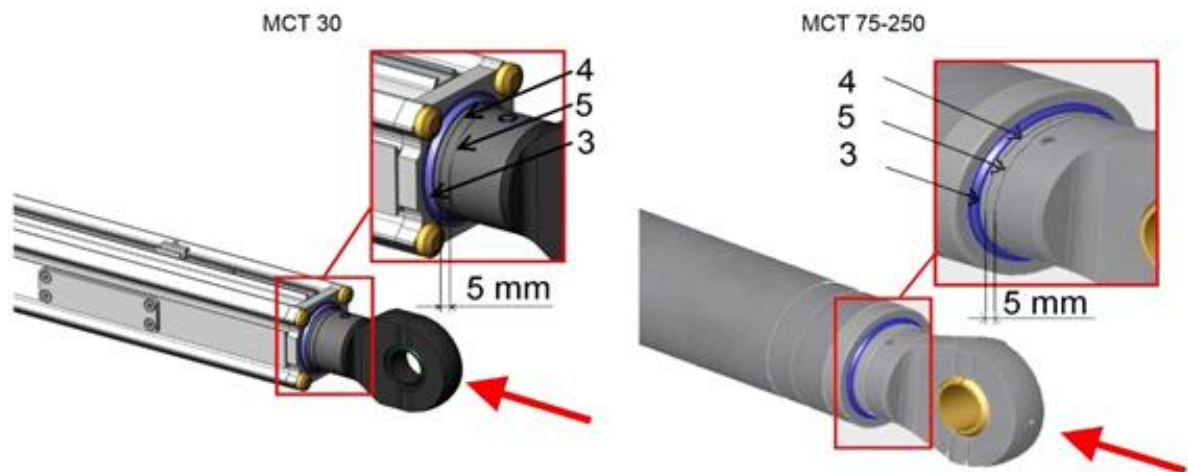

## 5.8 Maintenance

Regularly check that the electromechanical cylinder always stops before the warning zones (see the instructions in Section 5.6 Commissioning).

Regularly check that the electromechanical cylinder always stops before the external mechanical stops have been reached.

The trapezoid spindle of the electromechanical cylinder should be lubricated at least once every 24 months, or sooner if the number of cycles indicated below has been reached (see the table). Type of lubrication see **5.9 Lubricant**.

| Strokes (mm) | Cycles (lubrication interval) |
|--------------|-------------------------------|
| 0-300        | 5000                          |
| 301-600      | 2000                          |
| 601-         | 1000                          |



### WARNING!

**During all maintenance work on the electromechanical cylinder, the power source must be disconnected**

### Lubrication trapezoid spindle/tube MCT 30:

Run the electromechanical cylinder to the outer position.

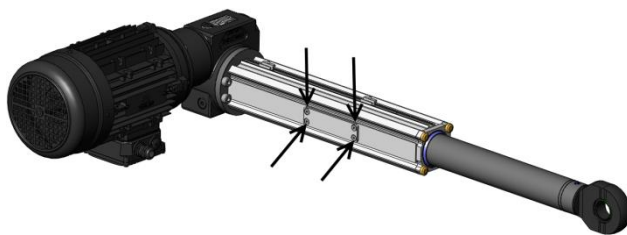

Loosen the M5 screws.

Remove the inspection hatch.



Lubricate the trapezoid spindle and the inside of the square tube through the opening with a plentiful amount of grease.

The electromechanical cylinder gear case is normally lubricated for life. The lubricant level should be at least halfway up the worm wheel or should cover the entire worm screw.



**Lubrication trapezoid spindle/tube MCT 75-250:**

Run the electromechanical cylinder to reach its lubricating position.

| Lubricating position (mm from the retracted position) |               |
|---|---------------|
| MCT 75  | X=12 to 28mm  |
| MCT 150   | X=12 to 28mm  |
| MCT 250   | X=88 to 107mm |

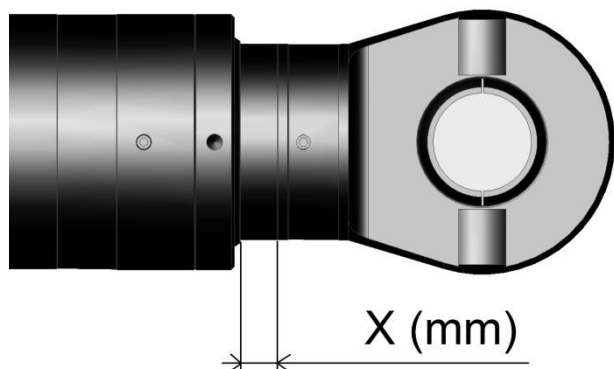

Lubricate the electromechanical cylinder through the nipple, approx. 100g / 1000mm stroke (don't use more grease than is recommended).

The electromechanical cylinder gear case is normally lubricated for life. The lubricant level should be at least halfway up the worm wheel or should cover the entire worm screw.



## 5.9 Lubricant

The machine plate specify the type of lubricant to be used in the electromechanical cylinder gear case.

The electromechanical cylinder gear case have a one-time lubrication on delivery and the lubricant does not need to be replaced during normal operations.

Lubrication gear case quantity:

| Electromechanical cylinder size | MCT30 | MCT75 | MCT150 | MCT250 |
|---------------------------------|-------|-------|--------|--------|
| Quantity (Liters)               | 0.3   | 0.65  | 1.0    | 1.8    |

The trapezoidal spindle/tube is greased with:

Klüber Duotempi PMY45



**NOTE!**

**Never mix a synthetic lubricant with a mineral oil based lubricant.  
Refill only with the type of lubricant specified on the plate!**

**Use only the specified grease on the trapezoidal spindle.**

## 6. Appendix

### 6.1 Installation of the positions sensors on the MCT75-MCT250

(This only concerns cases where the electromechanical cylinder is ordered with sensors.)

At the time of the delivery the sensor assembly is not mounted on the actuator, so that the final position of the sensor assembly can be decided during the installation.

The sensor assembly can be attached in four different equally-spaced positions on the electromechanical cylinder. These are composed of four taped M10 holes at each end of the electromechanical cylinder. On the MCT150, the M10 Allen screw (Pos. 7) in the desired mounting position is removed and is replaced by the rear bracket of the sensor assembly.

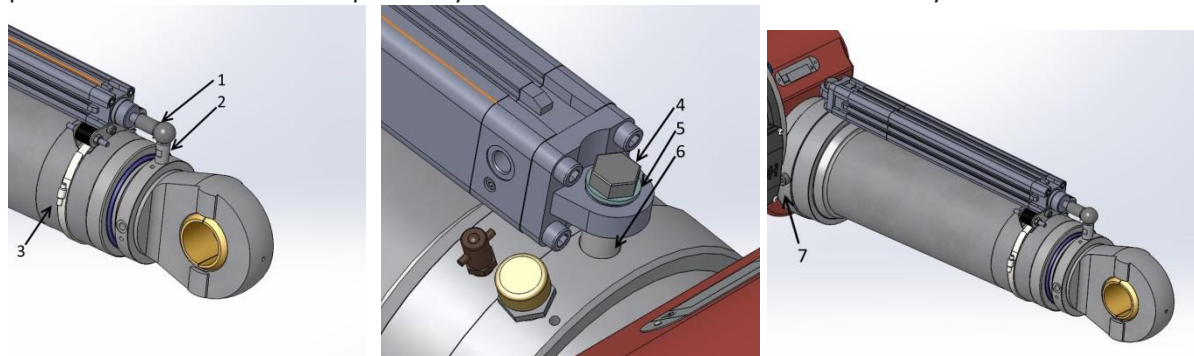

Assembly of the sensor unit:

1. Attach the ball (Pos. 2) in the threaded hole corresponding to the desired mounting position, then lock the threads with a Loctite 243 or equivalent.
2. Attach the rear bracket (Pos. 4-6) of the sensor assembly to the corresponding position on the electromechanical cylinder.
3. Remove the clip from the ball link (Pos. 1) and attach it to the ball (Pos. 2), then reinstall the clip.
4. In order to fix the middle bracket of the sensor assembly in place, the electromechanical cylinder is mounted in the brackets and the stroke is placed close to its inner position, then the brackets are aligned and the hose clamp is tightened (Pos. 3).



**WARNING!**

**When working on the electromechanical cylinder, the power source must be disconnected.**