

ELECTROMECHANICAL CYLINDERS

Original Instructions

Table of Contents

1. Health and Safety	3
1.1 Notice about safety.....	3
1.2 Warning devices.....	4
1.3 Warnings and cautions	4
2. Safety of the Machinery	4
2.1 When rebuilding the machine	4
2.2 Personnel requirements	4
2.3 Manufacturer	5
2.4 Mark	5
2.5 Working method in the event of an incident or breakdown.....	5
3. Noise	6
4. Safety Instructions	6
5. Electromechanical cylinder Description and Maintenance instructions	7
5.1 Product description	7
5.2 Drawing	7
5.3 Usage.....	7
5.4 Handling	8
5.5 Storage and Transport	8
5.6 Installation instructions.....	9
5.7 Commissioning.....	10
5.8 Maintenance.....	12
5.9 Lubricant.....	15
6. Appendix	15
6.1 Installation of the position sensors MCT75-MCT250.....	15
6.2 Run-in procedure MCT20-MCT250	16
6.3 Direction of movement	17
6.4 Manual operation.....	18
6.5 Maximum permissible loads	19

1. Health and Safety

These operating instructions contain the information necessary for the daily work of the operator responsible for the handling and usage of the equipment.

The operating instructions must be available to the persons involved in the operation of the equipment.

It is important that:

- The operating instructions and other applicable documents are retained throughout the lifetime of the equipment.
- The operating instructions and other applicable document are included as part of the equipment.
- The operating instructions are passed on to all other users of the equipment.
- The operating instructions are updated following any additions or changes to the equipment.
- The operating instructions describe the methods required in the use of the equipment.

1.1 Notice about safety

Before you start to use the equipment, or to perform maintenance or servicing of the equipment, please read the relevant parts of these instructions.

Pay attention to all the Danger, Prohibition, Edict, and Note textboxes mentioned in this manual.

Serious damage to persons and machinery can occur if this information is not observed.

The machinery is intended for use by an authorised operator.

Consider all electrical equipment to be live.

Consider all the hoses and pipes to be pressurised.

During servicing and maintenance of the equipment / machine, ensure that the source of power to the electricity, pneumatics (air) and hydraulic is broken before any maintenance is performed. The machine must be vented and the safety switch should be locked.

Servicing and maintenance should only be performed by qualified service personnel.

Follow the instructions in terms of the maximum loads, and see the decal on the equipment for the technical data.

1.2 Warning devices

Annual checks of warning devices and protective devices must be implemented to maintain control of their function and status.

1.3 Warnings and cautions

The Danger, Prohibition, Edict and Note textboxes contain information that is of importance in this manual:

(see the pictures below).

	DANGER! Ignoring this information will result in immediate danger to life!!
---	---

	PROHIBITION! Prohibited act associated with death or serious injury!
---	--

	DECREE! Correct use of personal protective equipment or other aids.
---	---

	NOTE! Information that requires extra attention!
--	--

2. Safety of the Machinery

The machine is labelled with a CE mark, see 2.4, which means that it has been designed, constructed and described in accordance with the EU Machinery Directive 2006/42/EC.

2.1 When rebuilding the machine

If the machine is rebuilt or supplemented with other parts that are not approved by the manufacturer, the CE mark does not apply for the parts that have changed the machine's functions. Warning labels and the CE mark must be clearly visible on the machine. If the warning label for a machinery part is replaced, then the new warning label should be installed in the same place as before.

Damaged decals and CE marks must be replaced immediately.

If the machine is rebuilt or parts are added, it is very important that these instructions are immediately completed / adjusted with the necessary illustrations, photographs and texts.

2.2 Personnel requirements

To avoid damage or injuries, the operator and operating personnel must be specifically instructed or trained according to the manufacturer's instructions. Operators and operating staff may only handle those parts that they have been instructed or trained to use.

All controls and keys shall be operated by hand and should never be activated by means of another kind, unless it is otherwise provided.

2.3 Manufacturer

This machine is manufactured by:
Swedrive AB
341 51 Lagan
SWEDEN

2.4 Mark

This machine is supplied with the following machine plate:

SWEDRIVE		CE	
Art.	<input type="text"/>	Thread	<input type="text"/>
No.	<input type="text"/>	YYWW	<input type="text"/>
Wgt kg	<input type="text"/>	Dyn load	<input type="text"/>
		kN st	<input type="text"/>
		%Ed	<input type="text"/>
Stroke	<input type="text"/>	mm i	<input type="text"/>
		Type	<input type="text"/>
Lubr.	<input type="text"/>		
SWEDRIVE AB, SE-341 51 LAGAN			

The serial number is given in the "No." field. This matches the Swedrive order number and must always be given in matters relating to the electromechanical cylinder.

2.5 Working method in the event of an incident or breakdown

The electromechanical cylinder is normally built into another machine and before starting up this machine, the operator and installer must be trained in the correct procedure in the event of an accident or breakdown on this machine.



If the following has happened, the electromechanical cylinder should not be used, contact Swedrive before the electromechanical cylinder perhaps could be put back into operation again.

- The electromechanical cylinder has been driven into external or internal stop.
- Movement between normally fixed parts can be observed.
- Temperatures above 100° C on the electromechanical cylinder have been measured.

If the following can be observed, the electromechanical cylinder should not be used before the cause has been investigated. If necessary, contact Swedrive.

- External damage to the electromechanical cylinder can be observed.
- The electromechanical cylinder does not move during commissioning of the motor.
- The motor power has for a long time continuously increased during operation.
- Abnormal noise during operation.

If an electric motor, hydraulic or holding brake is used, see the respective operating manual for working methods in the event of an accident or breakdown.

In the event of an accident with personal injury, call 112 immediately and contact healthcare.

3. Noise

This machine features a continuous A-weighted sound pressure level that is below 70 dB (A).

4. Safety Instructions

- The machine may only be used by trained personnel and when the user has read and understood the contents of the current operating instructions.
- The machine may only be used for its predetermined purposes and only with the installed protection devices. All applicable safety regulations must be observed.
- Daily maintenance work must be performed by trained personnel.
- Electrical work must only be performed by trained personnel.
- Work on live electrical parts is not permitted.
- Rebuilds, repairs and modifications to the machine may only be performed under the applicable safety regulations.
- When repairs are performed, it is only permitted to use the original spare parts.

5. Electromechanical cylinder Description and Maintenance instructions

5.1 Product description

The electromechanical cylinder consists of gearbox (worm gear) that transfers the rotational motion to an axial motion. A spindle is fixed into the worm wheel. By rotating the worm wheel / spindle and by fixing the nut into the piston rod in combination with the rotational locking of the end eye of the electromechanical cylinder, then end eye will move axially.

There are two main types of electromechanical cylinders:

MCT where the electromechanical cylinder uses a trapezoidal spindle for the axial movement.

MCK where the electromechanical cylinder uses a ball screw for the axial movement.

5.2 Drawing

If the field "Type" on the machine plate starts with no. 9 or G, contact Swedrive for correct drawing. For other electromechanical cylinders, see drawings in Swedrive's electromechanical cylinder catalogue.

5.3 Usage

The electromechanical cylinder is designed to move loads horizontally (pull / push) or vertically (raise / lower). Only the axial forces should affect the electromechanical cylinder. Therefore, the load must be steered so that no radial forces will affect the electromechanical cylinder (see point 3 of the Installation Instructions).

If there is a risk of personal injury or if unwanted damage to the machinery could occur, the electromechanical cylinder should be supplemented with another safety system. Other uses of the electromechanical cylinder than those described above may only be done with the permission of the manufacturer.



Warning! If the electromechanical cylinder is assembled in such a way that people are at risk of injury from contact with the piston rod when it is in motion, the builder of the machine is responsible for ensuring that the piston rod is protected against any such contact.

None of Swedrive's electromechanical cylinders are fully dynamic self-locking.

If you are unsure about self-locking, contact Swedrive.

MCT Electromechanical cylinders with single pitch on the trapezoidal spindle are good static self-locking. If absolute static self-locking is required, supplement the electromechanical cylinder with a holding brake.

MCT Electromechanical cylinders with double pitch on the trapezoidal spindle are not statically self-locking, these should be supplemented with a holding brake.

MCK Electromechanical cylinders with the ball screw are not statically self-locking, these should be supplemented with a holding brake.

Use an electromechanical cylinder of the right size - if unsure, check against our electromechanical cylinder catalogue, see **6.5 Max permitted loads** or contact Swedrive.



WARNING:

The electromechanical cylinder alone is not a safety device. In cases where there is a risk of personal injury, the electromechanical cylinder should be supplemented with an alternative safety system.

5.4 Handling

When unpacking and installing the electromechanical cylinder, the weight of the electromechanical cylinder and the motor must be taken into consideration. See the electromechanical cylinder machine plate for information about the weight.

5.5 Storage and Transport

The electromechanical cylinder must be stored or transported in a way that will prevent exposure to rain, high temperatures, ozone or solar radiation which can cause premature aging of the rubber components. The relative humidity should be kept below 50% to minimise condensation on the electromechanical cylinder. At storage the ambient temperature should be in the range of 0 to +30° C. If a prolonged storage time, storage or transport with relative humidity above 50%, storage or transport in difficult conditions is necessary, please contact Swedrive for further information, also see storage and transport instruction SW3046.

5.6 Installation instructions

1. Make sure that the end eye is clean and filled with grease. If maintenance-free end eye is used, do not add lubrication.
2. If possible, mount the electromechanical cylinder in a retracted position to protect the piston rod.
3. The electromechanical cylinder must be free from any side forces. Side loads must be controlled with a guidance system, or similar, so that only the pull or push loads will affect the electromechanical cylinder.



4. Make sure that no stresses are built into the electromechanical cylinder during the assembly.
5. When combining multiple electromechanical cylinders with a drive motor, gearboxes and intermediate axles, these must be carefully aligned.
6. If the electromechanical cylinder (or electromechanical cylinders) is correctly mounted, you will be able to rotate the incoming shaft by hand when the electromechanical cylinder is unloaded.
7. Be sure to protect moving/rotating parts from accidental access.



8. If a sensor is used, think about the consequences of a malfunction / voltage loss!
9. If the electromechanical cylinder is mounted in a humid environment and powered by an electrical motor, on the electric motor ensure that the lowest of the drain plugs is opened.

5.7 Commissioning

1. Do not operate the electromechanical cylinder unless all limit sensors or possibly safety devices are installed and working properly.



NOTE!

Never run the electromechanical cylinder unless the end positions sensors are installed and working properly, see point 9.

2. If an electric motor/holding brake is used, it should be installed and commissioned according to its operating instructions. For instructions of electric motor wiring and direction of movement see **6.3 Direction of movement**.

Check that the actual voltage matches the specified voltage.

The staff member who connects the electricity should have the necessary skills and qualifications.



WARNING!

The staff member who connects the electricity should have the necessary skills and qualifications.

3. Prior to start up, check that there is sufficient lubricant in the gear case of the electromechanical cylinder. For the type and amount of lubricant, see **5.9 Lubricant**.
4. If permitted, it is advantageous to charge the electromechanical cylinder with only half the load from the start. After a number of runs, you can increase this to the full load. If abnormally high temperatures occur, investigate the cause and be aware of the risk of fire!
5. Make sure that the electromechanical cylinder never runs into external mechanical stop.



NOTE!

Never run the electromechanical cylinder into the external or internal mechanical stops. This could seriously damage the electromechanical cylinder.

6. Make sure that the electromechanical cylinder never runs into internal mechanical stops. The electromechanical cylinder has warning zones (see the pictures below) to allow the operator to visualize the danger and to avoid running into internal mechanical stops, in order not to damage the electromechanical cylinder. Therefore, during its operation, the operating distance must be adjusted so that the electromechanical cylinder never runs into the warning zones, see point 9.
7. Ensure that the electromechanical cylinder is not loaded with more load than the permissible load. Special consideration must be given to the maximum permissible buckling load. On standard mechanical cylinders, the name plate is specified with the maximum allowable dynamic operating load during a specified period of time (ED). See also **6.5 Maximum permissible loads**.
8. If issues with vibrations and noise occur when running a new electromechanical cylinder, make sure that the electromechanical cylinder are sufficiently lubricated, see **5.8 Maintenance**. If the type is MCT electromechanical cylinder and the vibrations and noise issues still are not resolved, then see **6.2 Run-in procedure MCT20-MCT250** otherwise contact Swedrive.

9. Setting the end position sensors:

If a more precise end position positioning is desired, we recommend driving the unit via a frequency converter to have the possibility to ramp the operation and thus avoid a variable rollout. The length of the rollout distance increases at higher movement speeds of the electromechanical cylinder.

If the electromechanical cylinder is equipped with manual operation, this can in many cases be used for setting the end positions. See **6.4 Manual operation**.

Adjusting the end position sensor when driving the electromechanical cylinder outwards.

When Line 1 is visible outside the edge of Wiper 3, the electromechanical cylinder has reached the outer warning zone and the electromechanical cylinder must be stopped within 5 mm, before reaching Line 2. Driving outwards after reaching Line 2 will lead to electromechanical cylinder damage.

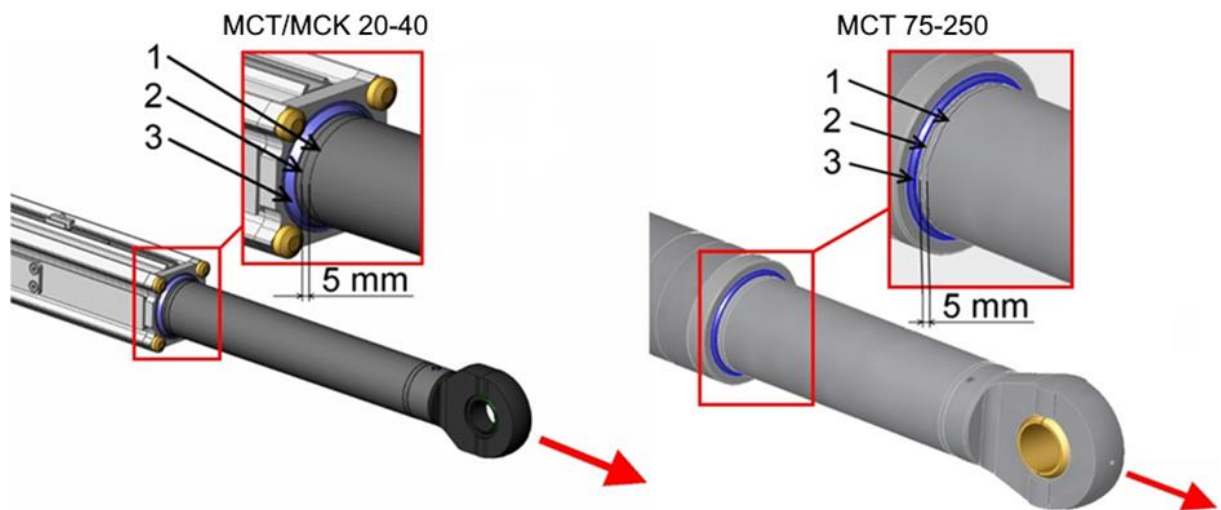

Adjusting the end position sensor when driving the electromechanical cylinder inwards.

When Line 4 reaches the edge of Wiper 3, the electromechanical cylinder has reached the inner warning zone and the electromechanical cylinder must be stopped within 5 mm, before reaching Line 5. Driving inwards after reaching Line 5 will lead to electromechanical cylinder damage.

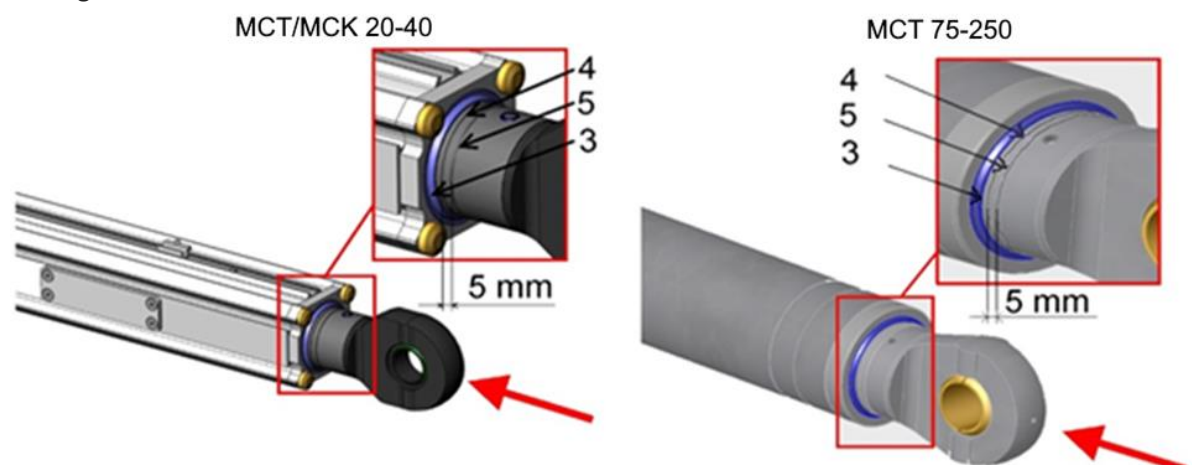

5.8 Maintenance

Regularly check that the electromechanical cylinder always stops before the warning zones (see the instructions in Section 5.6 Commissioning).

Regularly check that the electromechanical cylinder always stops before the external mechanical stops have been reached.

The MCT electromechanical cylinder's trapezoidal nut is subject to axial wear and must be controlled acc. to table below. If the maximum axial play has been reached, the electromechanical cylinder must be taken out of service to prevent uncontrolled movements.

The axial play is measured on the ear of the piston tube by subjecting the stationary electromechanical cylinder to external loads in alternating directions.

MCT size	20	30	40	75	150	250
Maximum axial play (mm)	1.5	1.75	1.75	2	2.25	2.5

The MCT/MCK electromechanical cylinder's trapezoid spindle/ball screw should be lubricated at least once every 24 months, or sooner if the number of cycles indicated below has been reached (see the table). Type of lubrication see **5.9 Lubricant**.

Stroke (mm)	MCT Cycles lubrication interval	MCK Cycles lubrication interval	MCT Cycles wear control interval
0-300	5000	45 000	10000
301-600	2000	23 000	4000
601-	1000	12 000	2000



WARNING!
During all maintenance work on the electromechanical cylinder, the power source must be disconnected

Lubrication of trapezoid spindle/ball screw/tube: MCT/MCK 20-40(standard) / MCT 20-40 WE (weather exposed)

Run the electromechanical cylinder to the outer position.

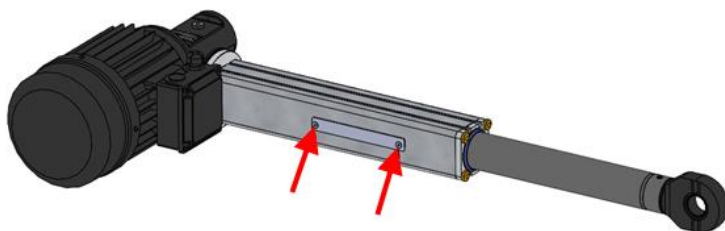

Loosen the M5 screws.
Remove the inspection hatch.



Lubricate the trapezoid spindle and the inside of the square tube through the opening with a plentiful amount of grease.

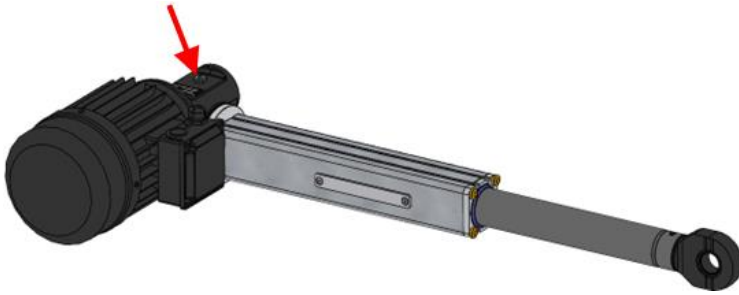

The electromechanical cylinder gear case is normally lubricated for life. The lubricant level should be at least halfway up the worm wheel or should cover the entire worm screw.

MCT 20-40 WE (weather exposed)

Run the electromechanical cylinder to the outer position.

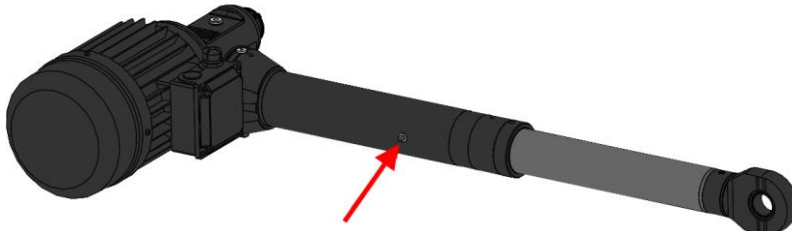

Lubricate the electromechanical cylinder through the nipple, approx. 100g / 1000mm stroke (don't use more grease than is recommended).

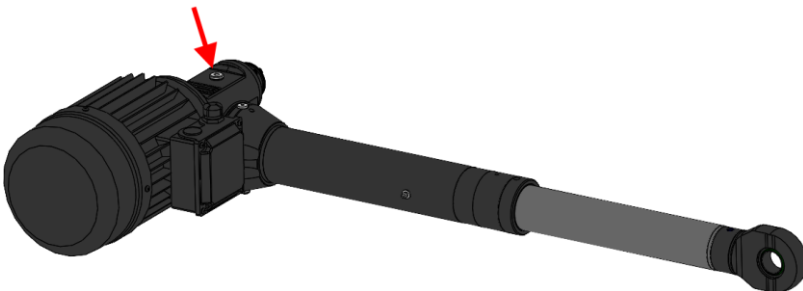

The electromechanical cylinder gear case is normally lubricated for life. The lubricant level should be at least halfway up the worm wheel or should cover the entire worm screw.

MCT 75-250 (standard) / MCT 75-250 WE (weather exposed):

Run the electromechanical cylinder to reach its lubricating position.

MCT size	75	150	250
Lubricating position from the retracted position	X=12 to 28 mm	X=12 to 28 mm	X=88 to 107mm

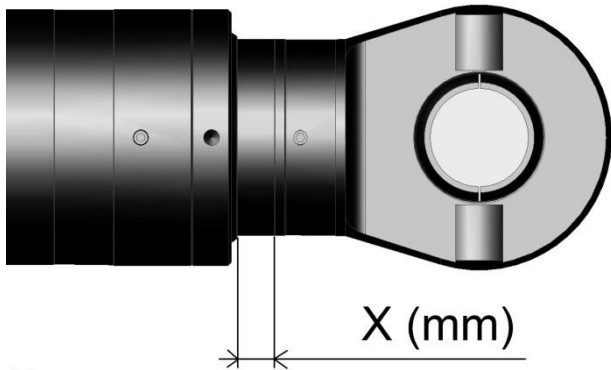

Lubricate the electromechanical cylinder through the nipple, approx. 100g / 1000mm stroke (don't use more grease than is recommended).



The electromechanical cylinder gear case is normally lubricated for life. The lubricant level should be at least halfway up the worm wheel or should cover the entire worm screw.

5.9 Lubricant

The machine plate specifies the type of lubricant to be used in the electromechanical cylinder gear case.

The electromechanical cylinder gear case have a one-time lubrication on delivery and the lubricant does not need to be replaced during normal operations.

Lubrication gear case quantity:

MCT/MCK size	20	30	40	75	150	250
Quantity (Liters)	0.1	0.3	0.3	0.65	1.0	1.8

The trapezoidal spindle/tube is greased with: Klüber Duotempi PMY45



NOTE!
Never mix a synthetic lubricant with a mineral oil-based lubricant.
Refill only with the type of lubricant specified on the plate!

Use only the specified grease on the trapezoidal spindle.

6. Appendix

6.1 Installation of the position sensors MCT75-MCT250

(This only concerns cases where the electromechanical cylinder is ordered with sensors.)

At the time of the delivery the sensor assembly is not mounted on the actuator, so that the final position of the sensor assembly can be decided during the installation.

The sensor assembly can be attached in four different equally spaced positions on the electromechanical cylinder. These are composed of four taped M10 holes at each end of the electromechanical cylinder. On the MCT150, the M10 Allen screw (Pos. 7) in the desired mounting position is removed and is replaced by the rear bracket of the sensor assembly.

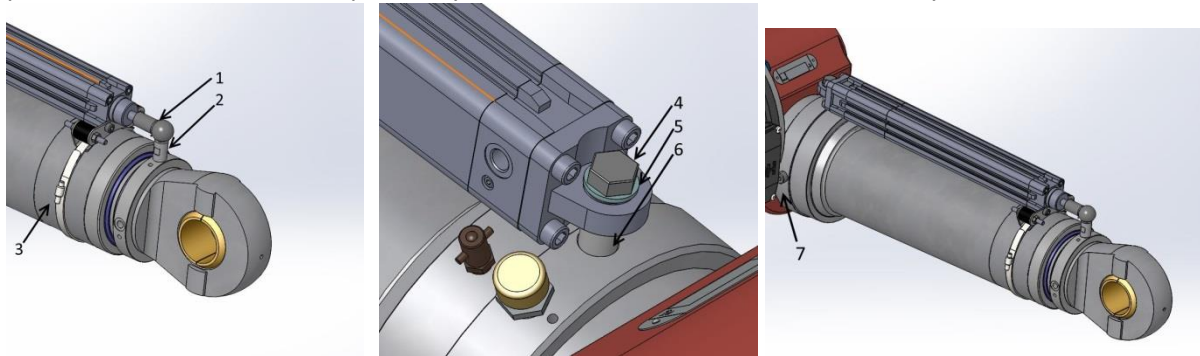

Assembly of the sensor unit:

1. Attach the ball (Pos. 2) in the threaded hole corresponding to the desired mounting position, then lock the threads with a Loctite 243 or equivalent.
2. Attach the rear bracket (Pos. 4-6) of the sensor assembly to the corresponding position on the electromechanical cylinder.
3. Remove the clip from the ball link (Pos. 1) and attach it to the ball (Pos. 2), then reinstall the clip.
4. In order to fix the middle bracket of the sensor assembly in place, the electromechanical cylinder is mounted in the brackets and the stroke is placed close to its inner position, then the brackets are aligned and the hose clamp is tightened (Pos. 3).



WARNING!
When working on the electromechanical cylinder, the power source must be disconnected.

6.2 Run-in procedure MCT20-MCT250

When manufacturing the trapezoidal spindle and the trapezoidal nut there will sometimes be a small deviation from correct form. This deviation from exact form could in rare cases in a new electromechanical cylinder result in vibrations and noise when running the electromechanical cylinder. After a short run-in, trapezoidal nut is paired to the trapezoidal spindle, which in most cases causes the vibrations or sounds to decrease or disappear completely.

Issues with vibrations and noise could also depend on the design of the machine in where the electromechanical cylinder is built in. But even in these cases a run-in could reduce the vibrations and noise issues in the machine.

Method

1. Run the electromechanical cylinder with half of maximum load if possible. If vibrations and noise occur when running the electromechanical cylinder, try to change speed or load to have a run-in without vibrations and noise.
2. Run the electromechanical cylinder for about 10 min. If the heat on outer tube is not above 40° degree Celsius the running time could be extended.
3. Let the electromechanical cylinder cool down for 2 hours. If no heat is detected the cooling down time could be reduced.
4. Regrease the electromechanical cylinder, see chapter 5.8 Maintenance.
5. Run the electromechanical cylinder at used load and speed and listen if the vibrations and noise is gone. If not, do the run-in procedure again and proceed to point 1.
6. If the vibrations or noises do not disappear despite repeated running-in attempts, contact Swedrive.

6.3 Direction of movement

When wiring an electrical motor, the wiring sequence will affect the rotation direction of the motor and there for the direction of movement of the electromechanical cylinder, see pictures.

Motor orientation: Right(standard)

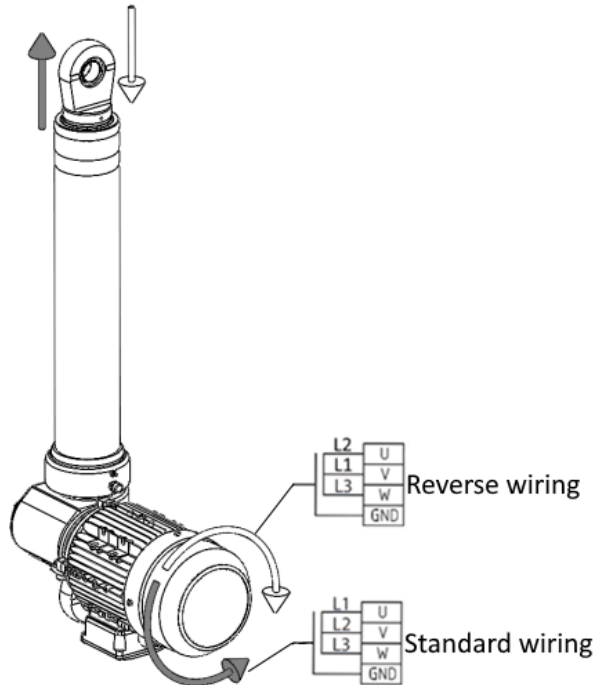

Motor orientation: Left

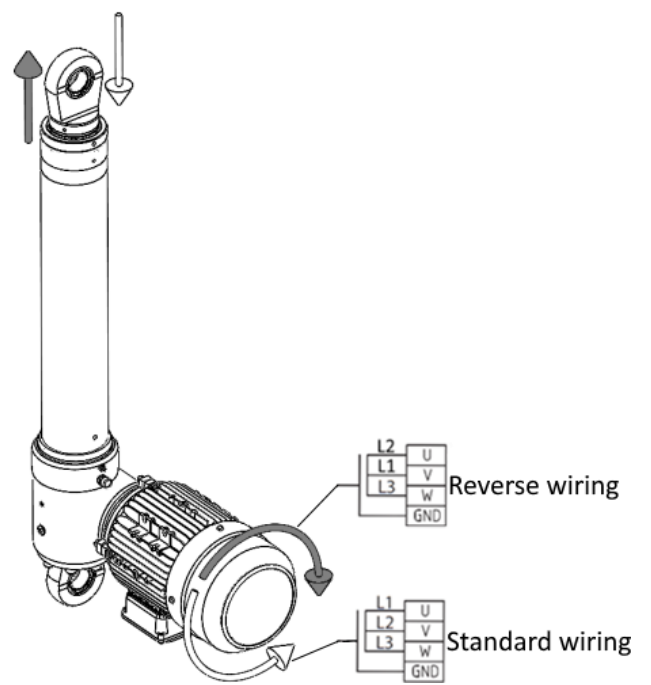

WARNING!

The staff member who connects the electricity should have the necessary skills and qualifications.

6.4 Manual operation

Manual operation could be used to maneuver the electromechanical cylinder when there is a power failure. Manual operation could also be used to set position of sensors or to maneuver out from mechanical stop. Integrated manual operation is not standard and must be specified when ordering.

If a motor with holding brake is used, you need to disengage the brake, see brake manual. When disengaging the brake make sure that the machine in with the electromechanical cylinder is mounted is secured, so no unwanted movement could occur.

Before doing any work on electromechanical cylinder be sure that the power source is disconnected.

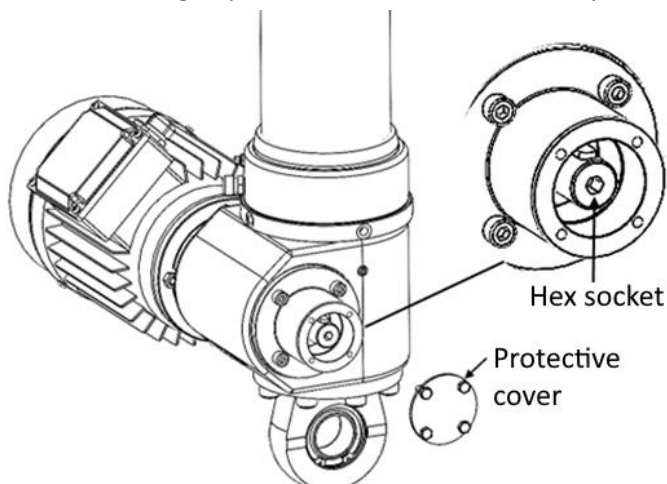

Integrated manual operation:

To manual operate the electromechanical cylinder, remove the protective plate and then use an allen key or a battery driven machine with allen key to drive the electromechanical cylinder.

For the input torque to be used on each type, see table. Don't use more torque than recommended torque, this could damage the electromechanical cylinder.

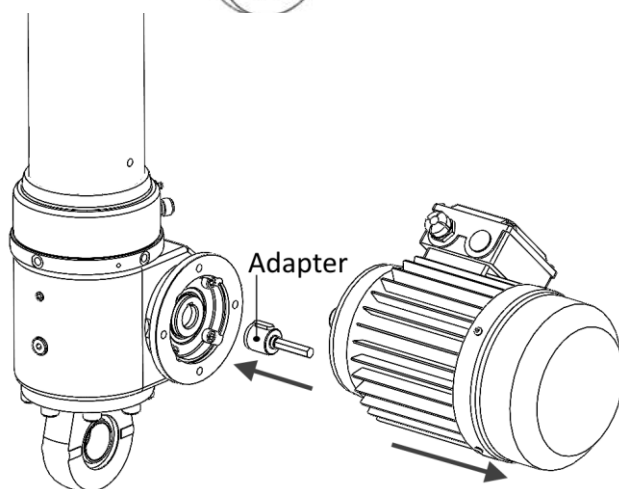

External manual operation:

If there is no integrated manual operation, manual operation can be carried out by detaching the existing motor and connecting an adapter to the electromechanical cylinder hole screw, which can then be operated with a battery driven machine. For the input torque to be used on each type, see table. Don't use more torque than recommended torque, this could damage the electromechanical cylinder. If a motor with sensor is used, consider the possible effects of manual operation on the operation of the control system.

Size	MCT (Nm)	MCK (Nm)	Adapter art.
20	5-10	2-4	92031771
30	10-15		92031772
40	10-15	4-8	92031772
75	30-50		92031773
150	50-80		92031774
250	100-150		92031775



WARNING:
During all manual operation, the power source must be disconnected.



WARNING:
If motor with holding brake is used, when disengaging the brake make sure that the machine in with the electromechanical cylinder is mounted is secured, so no unwanted movement could occur.

6.5 Maximum permissible loads

Ensure that the dynamic, static and compressive loads of the electromechanical cylinder are not exceeded. If these have been exceeded, see **2.5 Working method in the event of an incident or breakdown**.

For maximum permitted dynamic load at part of an hour (ED)* see machine plate. If nothing is stated on the machine plate, contact Swedrive for maximum permitted loads. For maximum permissible static and maximum permissible compressive load see table and charts below.



Note that the maximum permitted compressive dynamic/static loads in the outer positions of the electromechanical cylinder is often lower than the maximum permitted dynamic load on the machine plate, this is due to buckling.

* ED=20% means that the maximum allowed dynamic operating time per hour is $0.2 \times 60 = 12$ minutes per hour at an ambient temperature of max 25° Celsius.

Maximum static load (for maximum static compressive load in outer positions see buckling charts below)

MCT/MCK size	20	30	40	75	150	250
Maximum static load (kN)	20	40	40	75	150	250

Maximum dynamic and static compressive load to avoid buckling:

MCT20

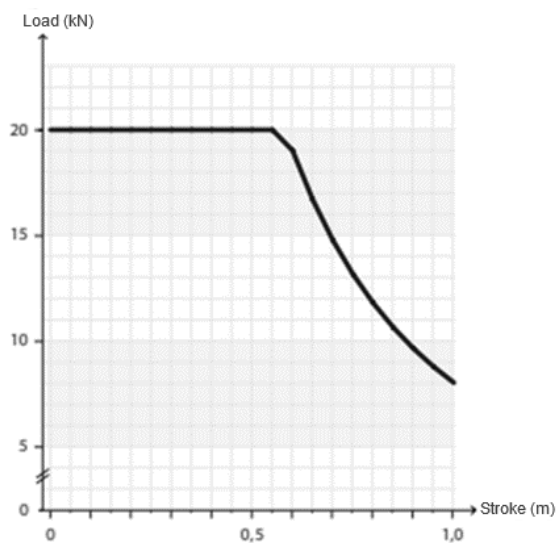

MCT30

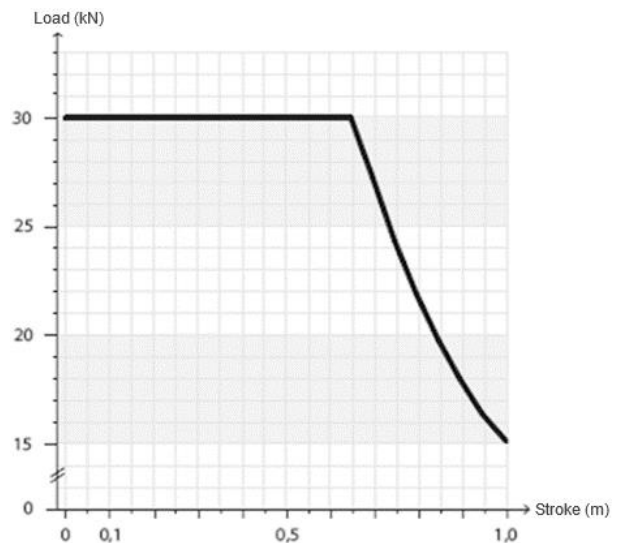

MCT40

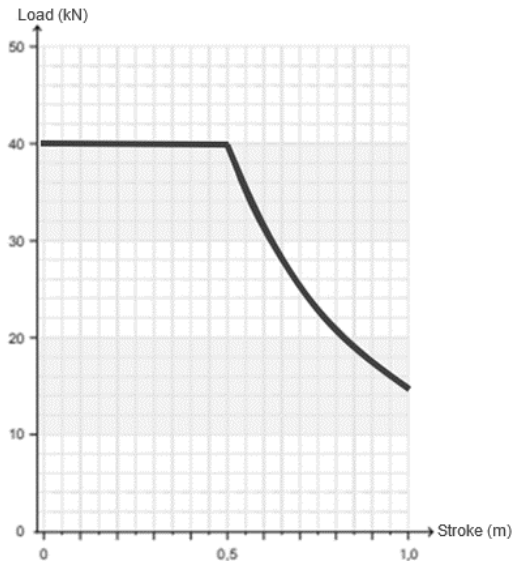

MCT75

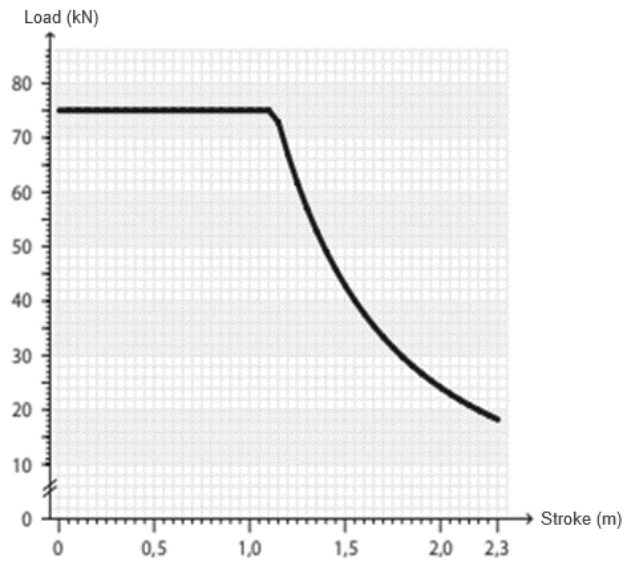

MCT150

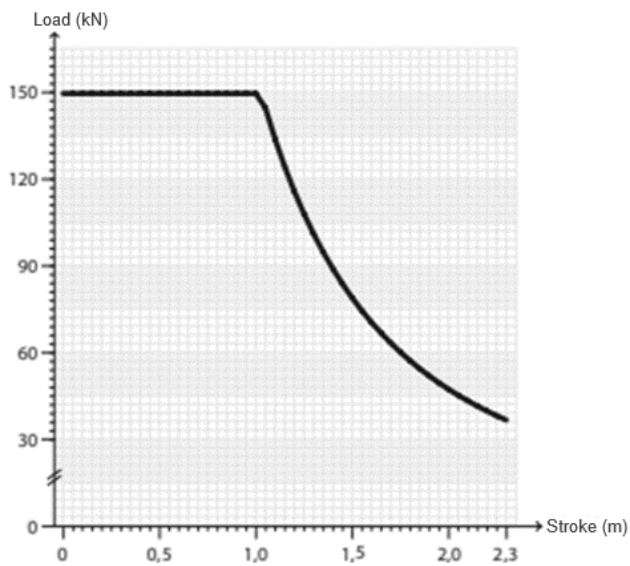

MCT250

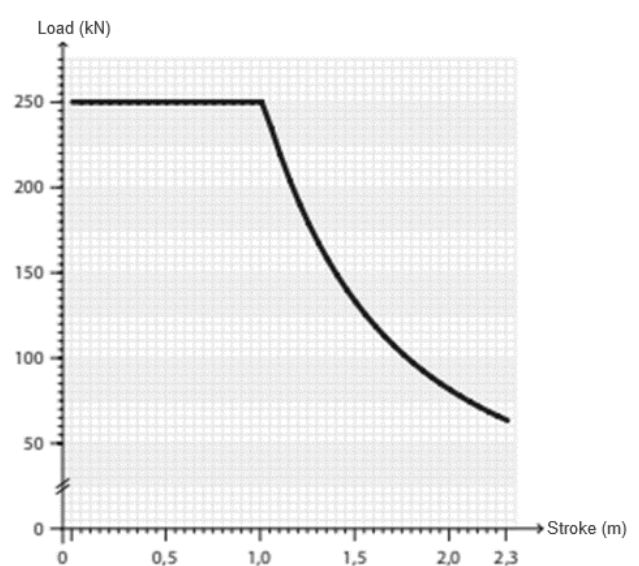

MCK20

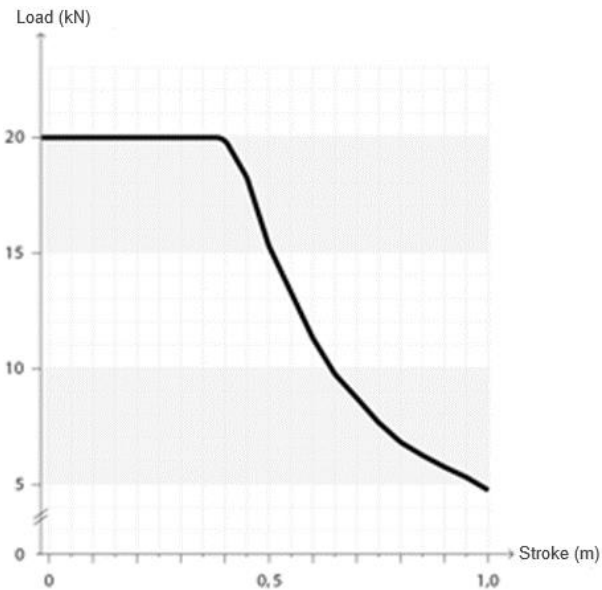

MCK40

